

INTRODUCTION

Career Goals

I will always seek out the career path that allows me to be the most creative and prolific, by contributing to solutions that are appropriate, thoughtful, and effective.

EDUCATION

BFA (Industrial Design), 2005

Columbus College of Art and Design
REF: Tom Kier, tkier@ccad.edu

Industrial Design Internship, 2004

(see Hewlett-Packard below)

PROFESSIONAL

Independent Consulting, 2009-[current]

Industrial Design, product visualization, training

Bose Corporation, 2007-2009

Industrial Designer, Advanced Development
Consumer research and product innovation, focused on future products and technologies.
REF: Gustavo Fontana, gustavo.fontana@bose.com

Black & Decker, 2005-2007

Industrial Designer
Consumer research, innovation, and design for power tools and home cleaning products.
REF: Chris Murray, christopher.murray@bdk.com

Hewlett-Packard, 2004

Industrial design internship, Hewlett-Packard mobile computer group; Houston, TX.
REF: Kevin Massaro, kevin.massaro@hp.com

Selected Freelance Clients:

The Coleman Company, Inc: Graphic ('07...)

Carbon Design: Industrial Design ('05...)

Teague: Industrial Design ('05)

Yummy Media: Hybrid ('05...)

The Buzz Group: Industrial Design ('05)

Not About You Records: press ('03)

Strata-G: Corporate Identities ('02)

RECOGNITION

Awards:

2008 Red Dot® "Design Team of the Year," Bose Corp.
Many Patents in a variety of product areas
First Place: Road Talk portable electronics competition.
First Place: Duck® tape animal competition
CCAD Trustee Scholarship, 4 years
CCAD Foundation Excellence Award Scholarship
CCAD John C Geupel Scholarship for Excellence in ID
CCAD Deans List (8 smstrs), President's List (6 smstrs)
High School "Most likely to get into an argument" superlative

DESIGN TOOLS

2D Viz/Presentation

Adobe Photoshop
Adobe Illustrator
Ashlar Vellum (Graphite)
Adobe InDesign
QuarkXPress
Macromedia Freehand
Alias Sketchbook Pro

Web & Interactive

Adobe GoLive
Macromedia Dreamweaver
PHP/mysql
HTML/CSS
Cshell & C
TI Basic (geek-alert)

Physical Tools of Choice

2D: bic, felt tip, markers
3D: 5lb. foam & soft plasticine

3D Viz/Engineering

Dassault Catia V5
Dassault SolidWorks
McNeal Rhinoceros 3D
Alias Studio Tools
Newtek Lightwave 3D

OTHER

Founded Hicks-Gibbon Industries ('07)
Married ('06)
Member Downtown Sailing Center, Baltimore ('06)
Mosaic Church: weekly volunteer ('02-'05)
CCAD Saturday Art Classes: weekly volunteer teacher ('04)
YMCA Rockies K-3 day camp counselor ('03)
YMCA hike-master training ('03)
Weekly summer service projects in the Rockies ('03)

Other Interests:

Musician (drums, guitar); interested in all types of music
Figure drawing/painting and photography
Breakdancing, Motorcycling, Hiking, Rock-climbing, Spitwad-Marksmanship.

Current as of

02 Feb, 2009

oHern Cover Letter



To: Design Staff

From: Adam O'Hern
2440 Massachusetts Ave #10
Cambridge, MA 02140

2 Feb, 2009

To: Design Staff

Dear Design Staff:

I am a full-time freelance/contract industrial designer, currently based in Cambridge, MA.

- **Industrial Design contracting** (ideation, 2D and 3D sketching and visualization, 3D CAD development for manufacture in UG NX5, CATIA V5, SolidWorks, or Rhino)

- **final product visualization and photo-rendering** and Photoshop work (Luxology's Modo)

- **design software training seminars** (Adobe CS apps, UG NX5, Catia V5, SolidWorks, Luxology's Modo)

I hope to have the pleasure of working with you in the near future. Many thanks for taking a moment to look through my credentials and portfolio, and I look forward to hearing from you.

Best Regards,

Adam O'Hern
Industrial Designer
(614) 440-6304
<http://adam.theoherns.com>

From: Adam O'Hern
2440 Massachusetts Ave #10
Cambridge, MA 02140

2 Feb, 2009

To: Design Staff

Dear Design Staff:

I am a full-time freelance/contract industrial designer, currently based in Cambridge, MA.

- **Industrial Design contracting** (*ideation, 2D and 3D sketching and visualization, 3D CAD development for manufacture in UG NX5, CATIA V5, SolidWorks, or Rhino*)
- **final product visualization and photo-rendering** and Photoshop work (*Luxology's Modo*)
- **design software training** seminars (*Adobe CS apps, UG NX5, Catia V5, SolidWorks, Luxology's Modo*)

I hope to have the pleasure of working with you in the near future. Many thanks for taking a moment to look through my credentials and portfolio, and I look forward to hearing from you.

Best Regards,

Adam O'Hern
Industrial Designer
(614) 440-6304
<http://adam.theoherns.com>



VIAGRA[®]
(sildenafil citrate) tablets

INTRODUCTION

Career Goals

I will always seek out the career path that allows me to be the most creative and prolific, by contributing to solutions that are appropriate, thoughtful, and effective.

EDUCATION

BFA (Industrial Design), 2005

Columbus College of Art and Design
REF: Tom Kier, tkier@ccad.edu

Industrial Design Internship, 2004

(see Hewlett-Packard below)

PROFESSIONAL

Independent Consulting, 2009-[current]

Industrial Design, product visualization, training

Bose Corporation, 2007-2009

Industrial Designer, Advanced Development
Consumer research and product innovation, focused on future products and technologies.
REF: Gustavo Fontana, gustavo.fontana@bose.com

Black & Decker, 2005-2007

Industrial Designer
Consumer research, innovation, and design for power tools and home cleaning products.
REF: Chris Murray, christopher.murray@bdk.com

Hewlett-Packard, 2004

Industrial design internship, Hewlett-Packard mobile computer group; Houston, TX.
REF: Kevin Massaro, kevin.massaro@hp.com

Selected Freelance Clients:

The Coleman Company, Inc: Graphic ('07...)

Carbon Design: Industrial Design ('05...)

Teague: Industrial Design ('05)

Yummy Media: Hybrid ('05...)

The Buzz Group: Industrial Design ('05)

Not About You Records: press ('03)

Strata-G: Corporate Identities ('02)

RECOGNITION

Awards:

2008 Red Dot® "Design Team of the Year," Bose Corp.
Many Patents in a variety of product areas
First Place: Road Talk portable electronics competition.
First Place: Duck® tape animal competition
CCAD Trustee Scholarship, 4 years
CCAD Foundation Excellence Award Scholarship
CCAD John C Geupel Scholarship for Excellence in ID
CCAD Deans List (8 smstrs), President's List (6 smstrs)
High School "Most likely to get into an argument" superlative

DESIGN TOOLS

2D Viz/Presentation

Adobe Photoshop
Adobe Illustrator
Ashlar Vellum (Graphite)
Adobe InDesign
QuarkXPress
Macromedia Freehand
Alias Sketchbook Pro

Web & Interactive

Adobe GoLive
Macromedia Dreamweaver
PHP/mysql
HTML/CSS
Cshell & C
TI Basic (geek-alert)

3D Viz/Engineering

Dassault Catia V5
Dassault SolidWorks
McNeal Rhinoceros 3D
Alias Studio Tools
Newtek Lightwave 3D

Physical Tools of Choice

2D: bic, felt tip, markers
3D: 5lb. foam & soft plasticine

OTHER

Founded Hicks-Gibbon Industries ('07)
Married ('06)
Member Downtown Sailing Center, Baltimore ('06)
Mosaic Church: weekly volunteer ('02-'05)
CCAD Saturday Art Classes: weekly volunteer teacher ('04)
YMCA Rockies K-3 day camp councilor ('03)
YMCA hike-master training ('03)
Weekly summer service projects in the Rockies ('03)

Other Interests:

Musician (drums, guitar); interested in all types of music
Figure drawing/painting and photography
Breakdancing, Motorcycling, Hiking, Rock-climbing, Spitwad-Marksmanship.



reddot design award design team of the year 2008

A UNIQUE OPPORTUNITY

Bose Corporation is a unique place in the world of product development. I was hired in 2007 as a staff-level industrial designer in the “Advanced Development” group, working with research and development on future technologies and product concepts. Our focus was on technology and user experience innovation. During my time at Bose, it was awarded the Red Dot “design team of the year” award, following previous winners like Apple, Audi, and BMW. This was a tremendous honor, and a tribute to the fantastic work I witnessed at Bose.



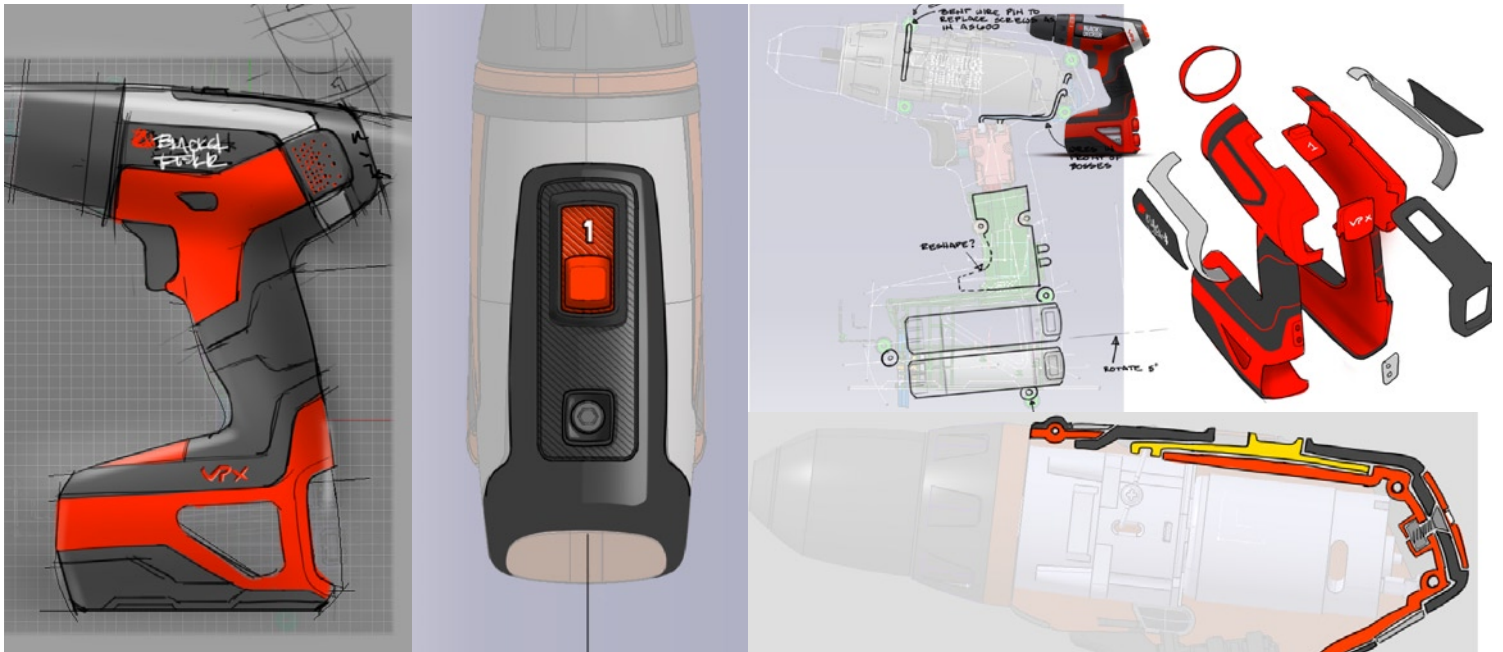

LOCK, STOCK, AND BARREL

Black & Decker has a long history with hand-held power drills. When they first invented the “pistol grip” drill in 1917, they changed the way power tools would be used from that moment forward. When developing the VPX system, we decided to start with the drill as the flagship product, and it was developed in tandem with the battery and charging systems, with a focus on appealing to a younger, fresher market. The resulting design was the most challenging and rewarding of my career thus far. Industrial design had huge influence on this project, designing the VPX logo, graphics, color scheme, “new” manufacturing techniques and mechanical designs, and even re-designing stock components such as the chuck.



o'hern VPX Battery System

07

<http://adam.theoherns.com>



B&D VPX BATTERY SYSTEM

This was “my baby” for my last year at Black & Decker in 2007. Beginning from the earliest conceptual phases of the design and product development process, I was honored with the opportunity of leading the industrial design team on the battery and charger design project. The initial phases involved exploring various battery architectures and connection schemes, and vetting them against hypothetical future products. The result is something I’m very proud of: a battery and charger that look “obvious”, and yet are utterly unlike anything else on the market. The latch system, “daisy-chain” charger system, and much of the mechanical assembly of these products were developed by the industrial design team.



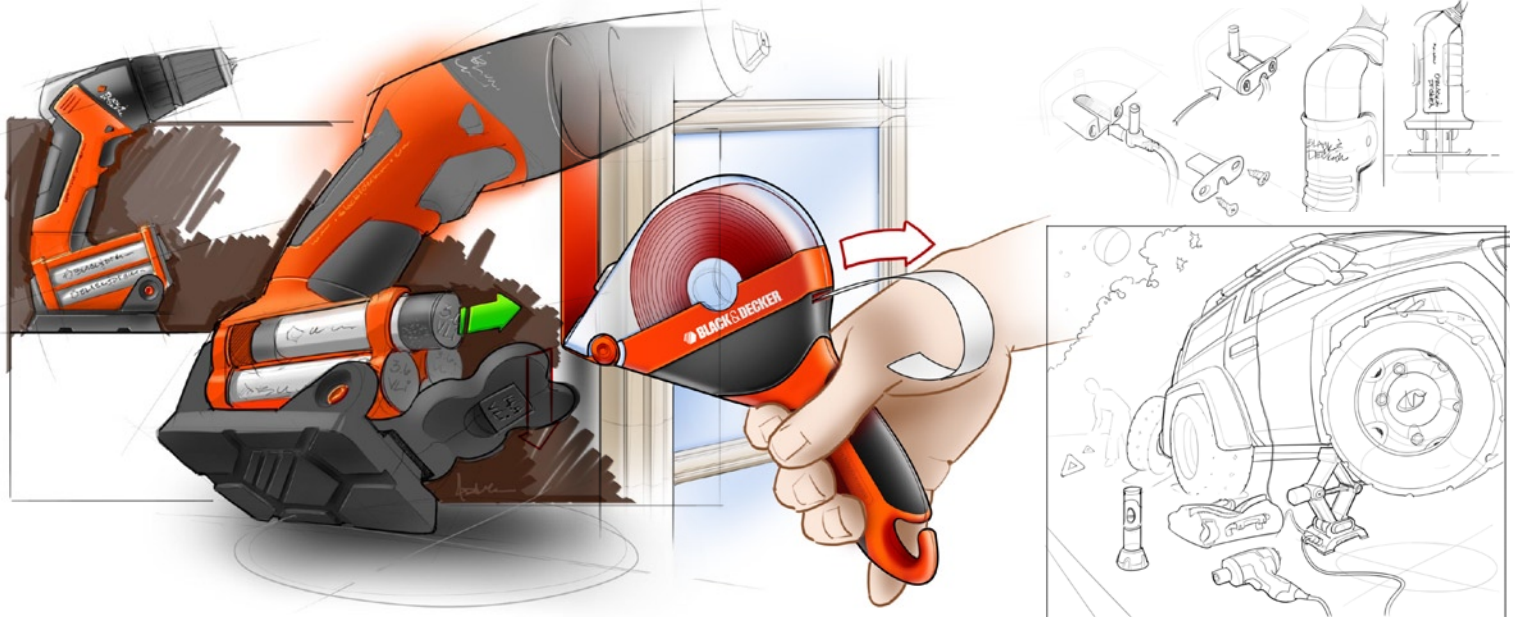

B&D PROCESS

At Black & Decker I often work with programs in their very earliest conceptual stages to create product ideas for research. I then work closely with engineers in Towson and China to develop the ideal "form factor" for the unit, and begin to understand the engineering requirements of the program. Exploring basic concepts through rough sketch-blitz sessions is followed by rough foam and clay modelling both by hand and by RP or machining, then final CAD data is produced (sometimes by myself, other times by our dedicated surfacing group). ID has a heavy influence on products at B&D because we are so central to the success of a program from conception to shelf.

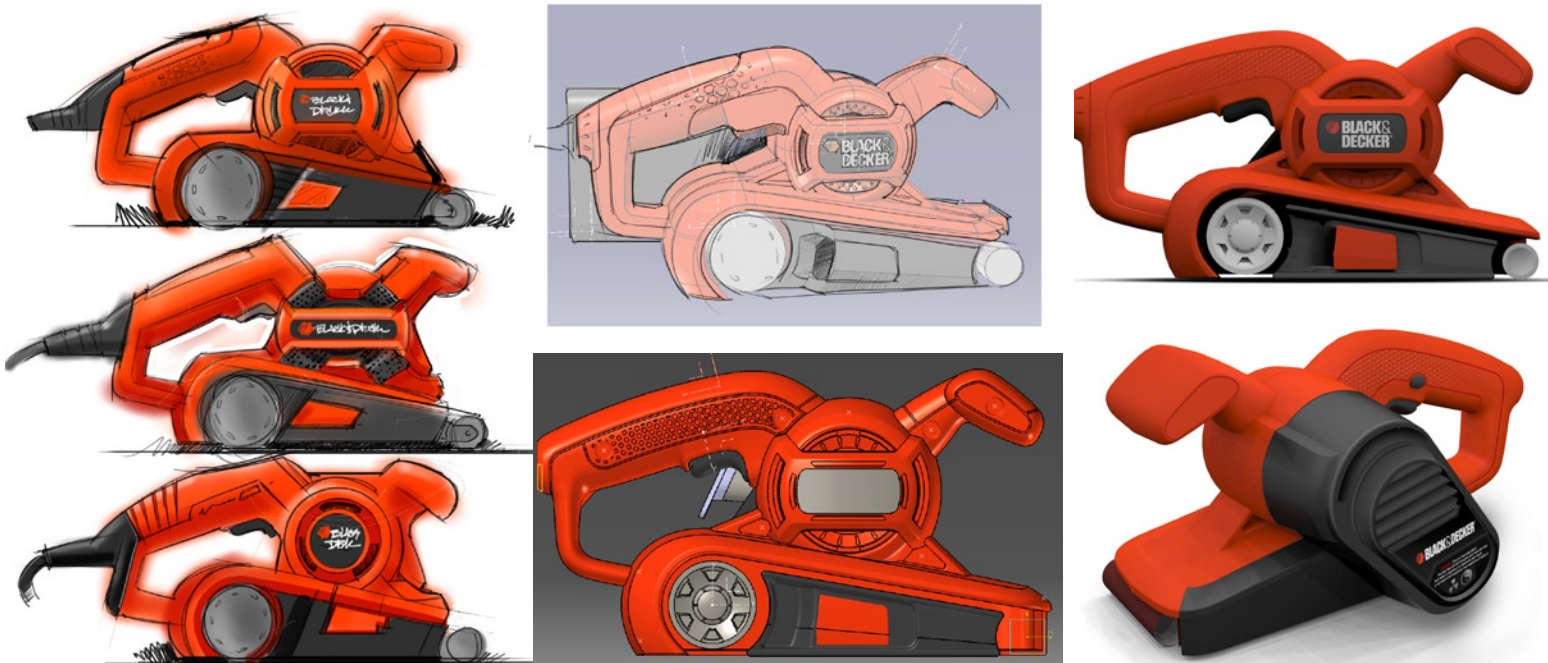

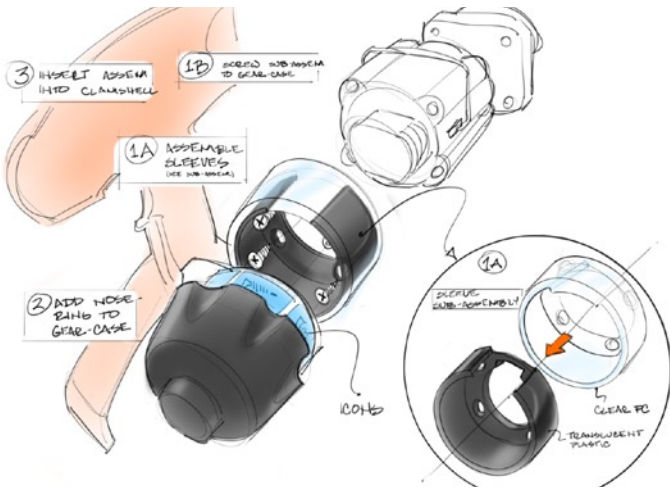

SMART SELECT DRILLS

Consumers can usually tell the difference between high and low speeds, but don't know which setting is appropriate to specific tasks. Most consumers don't even understand what a clutch mechanism does, much less how to take advantage of it. Enter Smart Select. The collar mechanism controls both speed and clutch stiffness to one of eight or nine graphically illustrated application-based settings. There were many challenges and limitations associated with this product. Everyone seems to have opinions about how a drill should look and work, in addition to being extremely cost-sensitive. Globally there are nine variants of this drill alone: designing for retailer exclusives is critical for B&D. This was part of an entire line of drills designed in collaboration with Tom Murray.



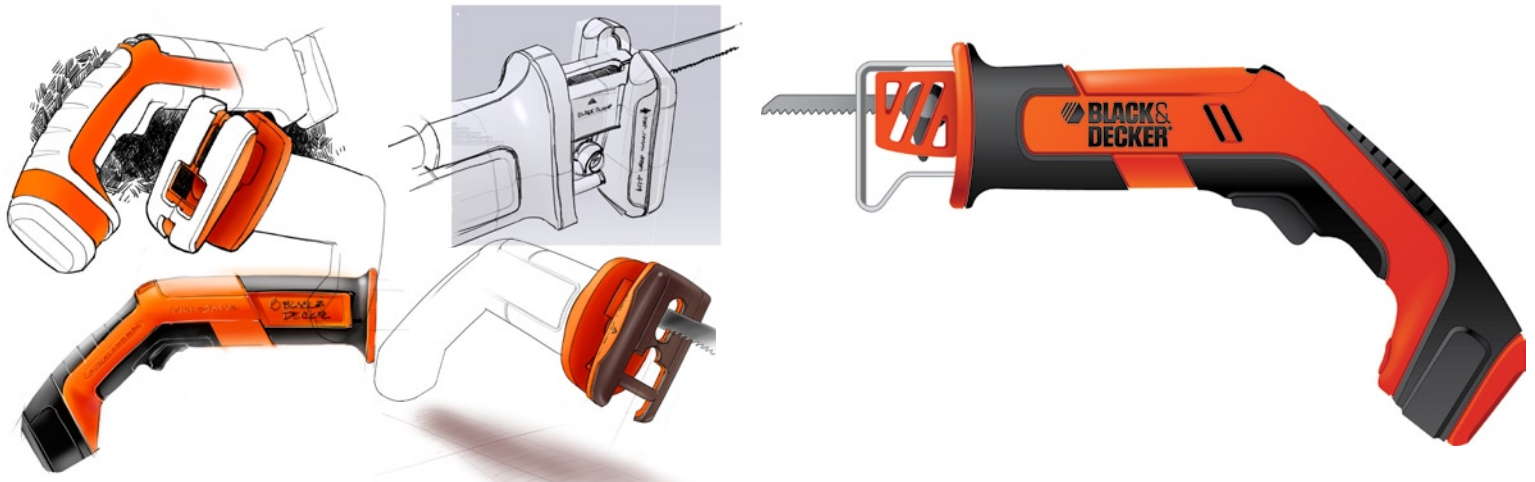

CUTTING MY TEETH

The Handisaw was my first project with the Black & Decker design team in Towson. This program taught me the fundamentals of designing for manufacture, and really stretched me in terms of ergonomic form development and came up with tricks to decrease the visual size of the unit. For example, the external shoe was originally designed by engineering as a part of the main housing, but opening it up made the unit appear much more compact.



FREELANCE PROCESS

The scope of my work with other companies varies greatly. I have worked with electronics manufacturers directly to begin projects from scratch, and I've worked through other designn consultancies to simply contribute to brainstorming and visualization efforts. My 2D rendering skills are often my greatest asset when working with remote clients.





NOT JUST A PC.

What you see here is more than a computer, it's a part of a system of home products I designed to work together in the digital home of 2010. While the details of the project are confidential, it was a broad-reaching program rethinking the way that computing power is distributed in the home. The "desktop replacement" product you see here was one of my designs. There were several other pieces. I am greatly indebted to HP for providing me the resources to carry this project to such lengths. I could not have done it without them.

